

CLEVIS PINS AND COTTER PINS (INCH SERIES)

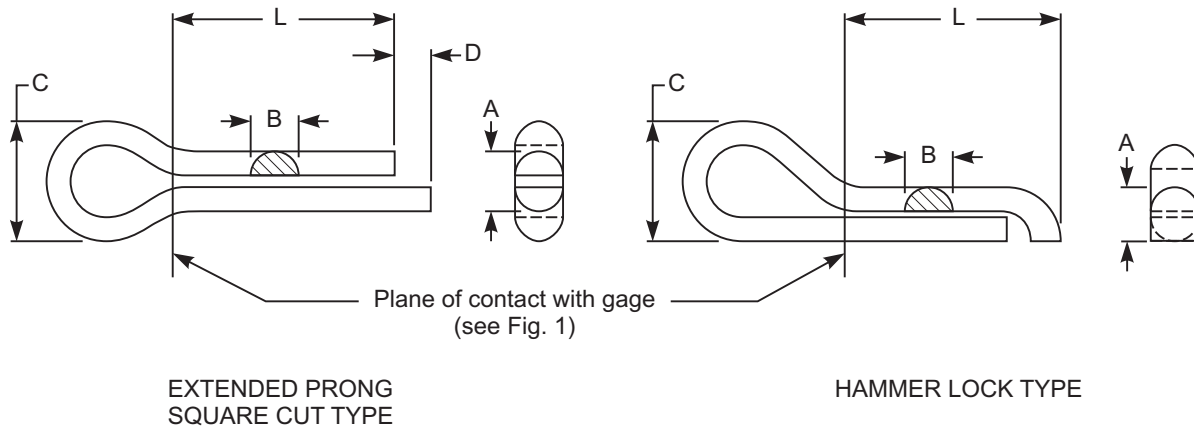

Table 4 Dimensions of Cotter Pins

Cotter Pin		A ₂		B		C	D	Gage Hole Diameter ±0.001
Size	Nominal	Total Shank Diameter		Wire Width		Head Diameter	Extended Prong Length	
		Max	Min	Max	Min	Min	Min	
1/32	0.031	0.034	0.028	0.032	0.022	0.06	0.01	0.047
3/64	0.047	0.050	0.044	0.048	0.035	0.09	0.02	0.062
1/16	0.062	0.063	0.056	0.060	0.044	0.12	0.03	0.078
5/64	0.078	0.079	0.072	0.076	0.057	0.16	0.04	0.094
3/32	0.094	0.093	0.086	0.090	0.069	0.19	0.04	0.109
7/64	0.109	0.107	0.100	0.104	0.080	0.22	0.05	0.125
1/8	0.125	0.124	0.116	0.120	0.093	0.25	0.06	0.141
9/64	0.141	0.138	0.130	0.134	0.104	0.28	0.06	0.156
5/32	0.156	0.154	0.146	0.150	0.116	0.31	0.07	0.172
3/16	0.188	0.180	0.172	0.176	0.137	0.38	0.09	0.207
7/32	0.219	0.212	0.202	0.207	0.161	0.44	0.10	0.241
1/4	0.250	0.230	0.220	0.225	0.176	0.50	0.11	0.275
5/16	0.312	0.286	0.275	0.280	0.220	0.62	0.14	0.343
3/8	0.375	0.341	0.329	0.335	0.263	0.75	0.16	0.413
7/16	0.438	0.412	0.400	0.406	0.320	0.88	0.20	0.482
1/2	0.500	0.480	0.467	0.473	0.373	1.00	0.23	0.550
5/8	0.625	0.605	0.590	0.598	0.472	1.25	0.30	0.688
3/4	0.750	0.730	0.715	0.723	0.572	1.50	0.36	0.825

GENERAL NOTE: For additional requirements, refer to General Data for Cotter Pins in paras. 1 and 3.

NOTES:

1. 5/64, 7/32, 7/16, and 3/4 not preferred for new design.
2. Total shank diameter, A, dimension is two times wire thickness. A is measured at end of pin where no gap is permitted.